

The Number 6

Read, colour and count.

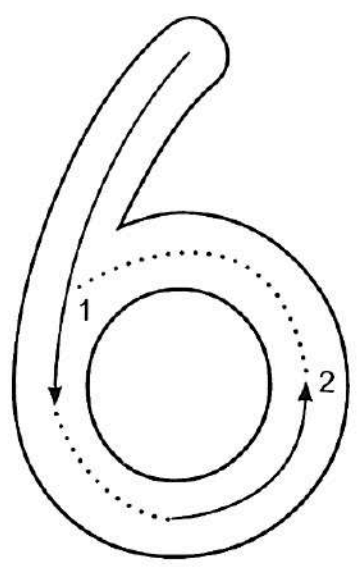

six



six pencils

Trace and write the number 6.



Skills developed:



Learning Objectives: Associating numbers and values, developing fine motor skills

Activity: Draw six big circles on the floor with a chalk and ask the children to jump on them. Ask them to read, colour, count and trace number 6.

The Number 7

Read, colour and count.

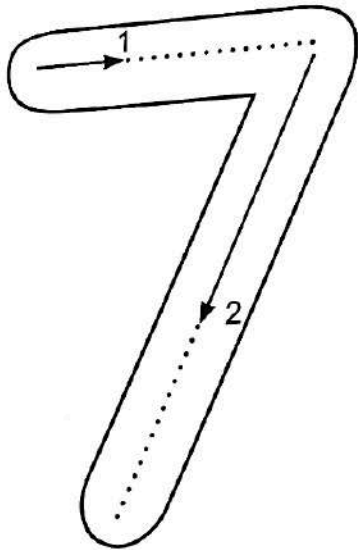

seven

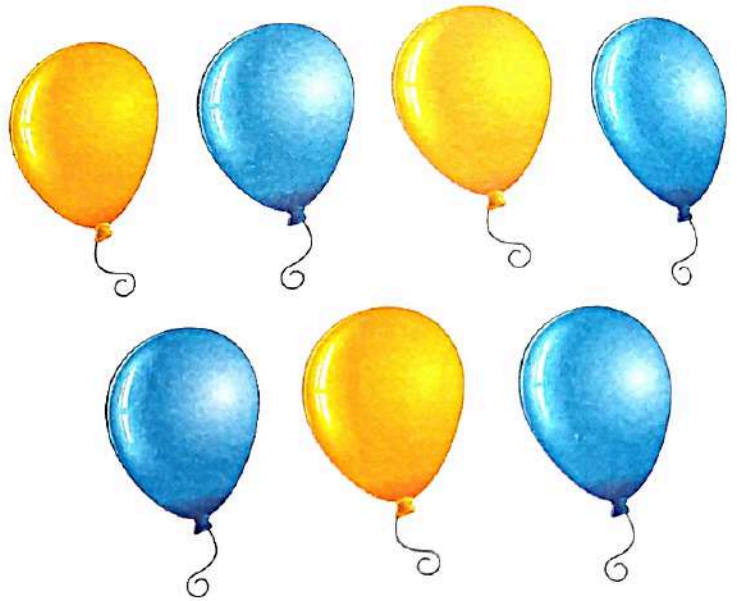

seven balloons

Trace and write the number 7.

TEACHER'S CORNER

Learning Objectives: Assess

Skills developed:

Scanned By Scanner Go



The Number 8

Read, colour and count.

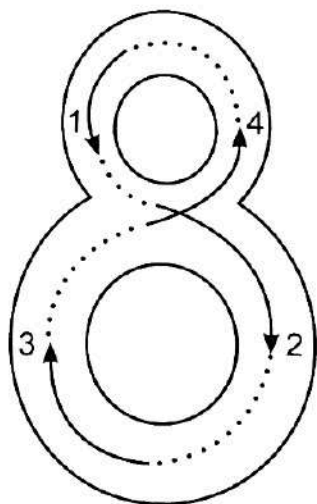

eight

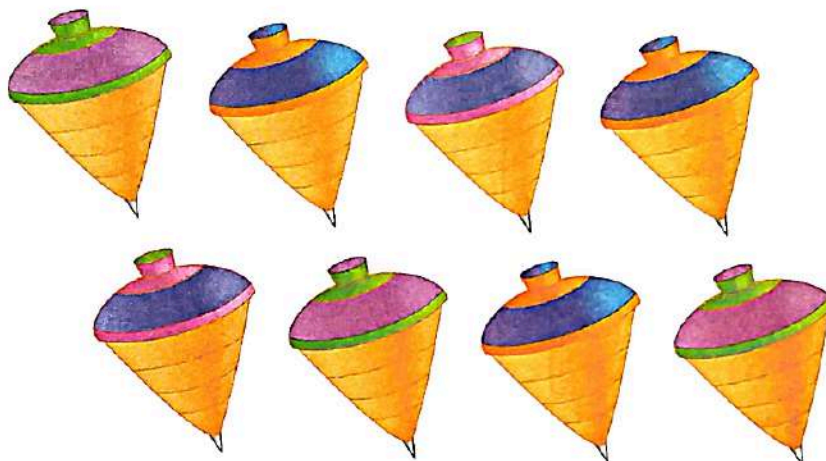

eight tops

Trace and write the number 8.

8				

TEACHER'S CORNER

Skills developed:



Learning Objectives: Associating numbers and values, developing fine motor skills

Activity: Ask the children to clap eight times in the class. Encourage them to count as they clap.

The Number 9

Read, colour and count.

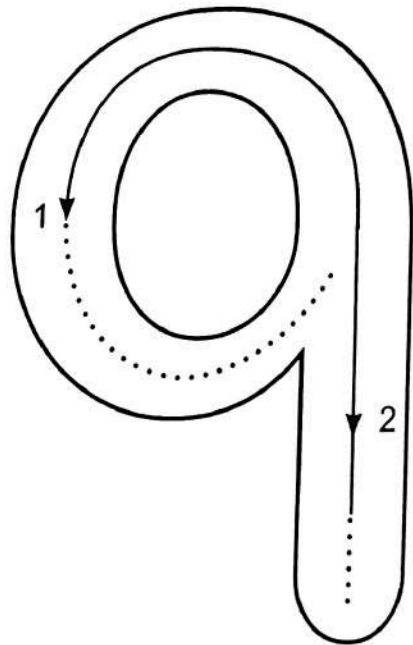

nine



nine cups

Trace and write the number 9.

The Number 0

Read, colour and count.

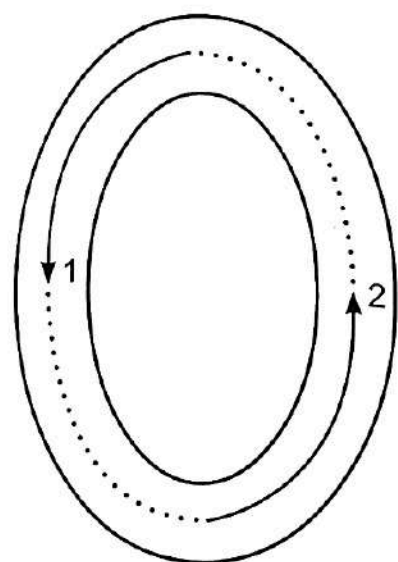

zero



This basket has 2 fruits.



This basket has no fruits.

We say, it has zero (0) fruits.

Trace and write the number 0.



The Number 10

Read, colour and count.

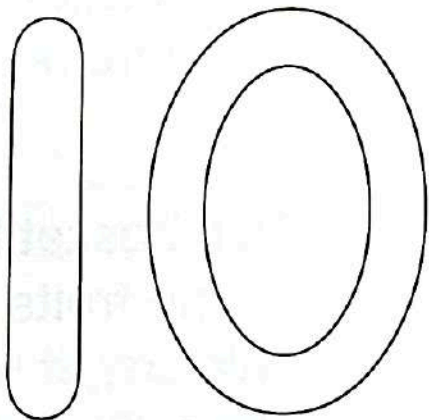

ten

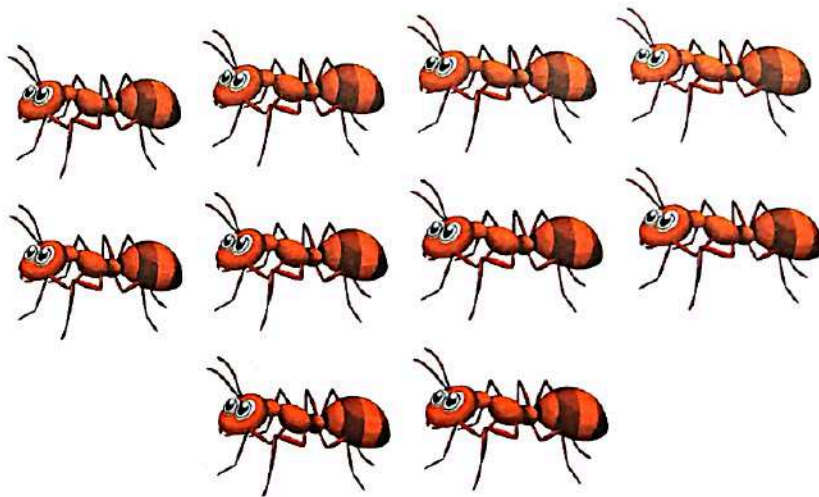

ten ants

Trace and write the number 10.

Revising 6-10

Trace and write numbers 6-10.

6	6			
7	7			
8	8			
9	9			
10	10			

